

REVISIONS

PART NO. NE

Orange ring color is the registered manufacturer's I.D. for Aztech Locknut Company. ¹

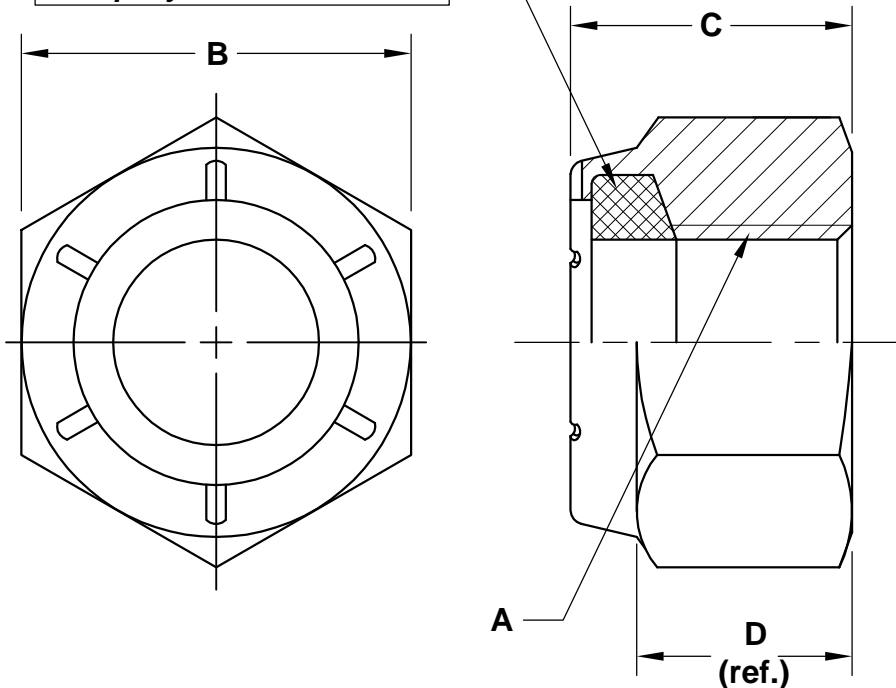

SIZE A	ZINC PLATED PART NUMBER	WIDTH ACROSS FLATS max / min B	THICKNESS max / min C	WRENCH HEIGHT D
1/4-20	25CNE-AZ	.439 - .430	.328 - .298	.225
1/4-28	25FNE-AZ			
5/16-18	31CNE-AZ	.502 - .492	.359 - .329	.250
5/16-24	31FNE-AZ			
3/8-16	37CNE-AZ	.564 - .553	.468 - .438	.335
3/8-24	37FNE-AZ			
7/16-14	43CNE-AZ	.627 - .616	.468 - .438	.324
7/16-20	43FNE-AZ			
1/2-13	50CNE-AZ	.752 - .741	.609 - .579	.464
1/2-20	50FNE-AZ			
9/16-12	56CNE-AZ	.877 - .865	.656 - .626	.469
9/16-18	56FNE-AZ			
5/8-11	62CNE-AZ	.940 - .928	.765 - .735	.593
5/8-18	62FNE-AZ			
3/4-10	75CNE-AZ	1.064 - 1.052	.890 - .860	.742
3/4-16	75FNE-AZ			
7/8-9	87CNE-AZ	1.252 - 1.239	.999 - .969	.790
7/8-14	87FNE-AZ			
1-8	100CNE-AZ	1.440 - 1.427	1.078 - 1.016	.825
1-14	100FNE-AZ			
1 1/8-7	112CNE-AZ	1.627 - 1.614	1.203 - 1.141	.930
1 1/8-12	112FNE-AZ			
1 1/4-7	125CNE-AZ	1.815 - 1.801	1.422 - 1.360	1.125
1 1/4-12	125FNE-AZ			
1 3/8-6	137CNE-AZ	2.008 - 1.973	1.609 - 1.547	1.282
1 3/8-12	137FNE-AZ			
1 1/2-6	150CNE-AZ	2.197 - 2.159	1.640 - 1.578	1.313
1 1/2-12	150FNE-AZ			

1. Alternate manufacturer's identification may be in the form of other colors.

NOTES

MATL.: STEEL

APPROVAL

QC VC 10-14-05

PREVAILING TORQUE PER IFI 100/107, WHERE APPLICABLE

NE NYLON INSERT LOCKNUT



DATE	DRAWN BY	SCALE	UNITS	DWG. TYPE	REV.
9-30-05	MP	NONE	INCH	S	0