

REVISIONS

PART NO. RFTF

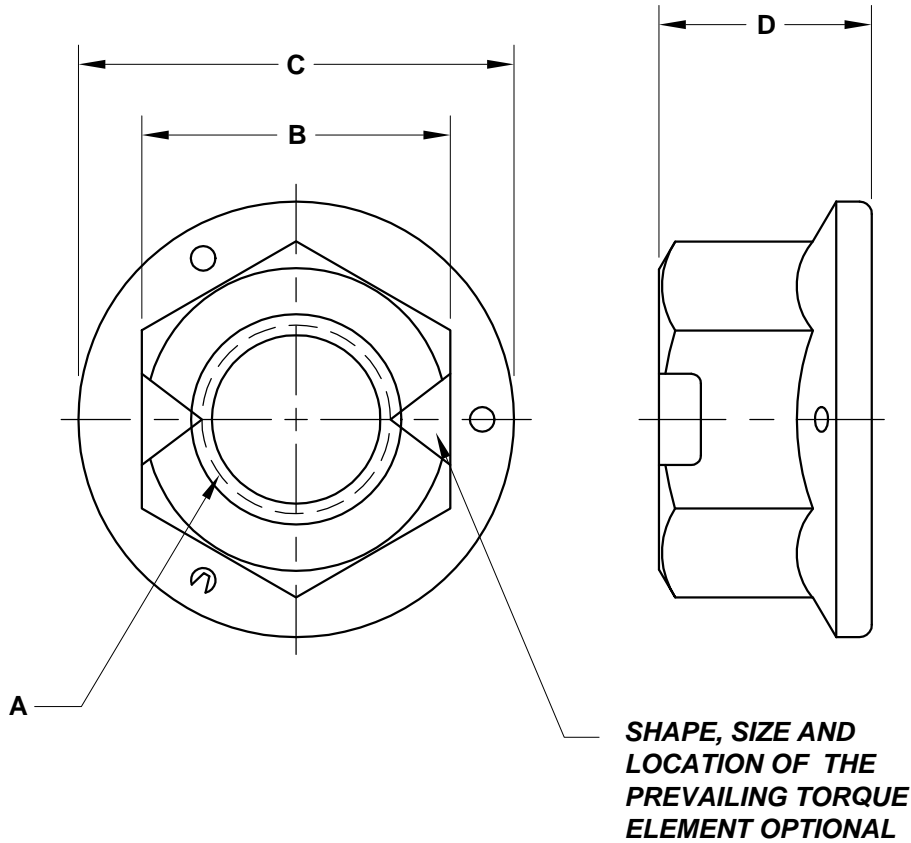

SIZE A	ZINC PLATED PART NUMBER	WIDTH ACROSS FLATS B	FLANGE DIAMETER C	NUT THICKNESS D
3/8-16	37CRFTFZ	.5645 - .551	.810 MAX.	.425 MAX.
3/8-24	37FRFTFZ			
7/16-14	43CRFTFZ	.6895 - .675	.930 MAX.	.495 MAX.
7/16-20	43FRFTFZ			
1/2-13	50CRFTFZ	.752 - .736	1.070 MAX.	.555 MAX.
1/2-20	50FRFTFZ			
9/16-12	56CRFTFZ	.877 - .861	1.190 MAX.	.625 MAX.
9/16-18	56FRFTFZ			
5/8-11	62CRFTFZ	.9395 - .922	1.330 MAX.	.690 MAX.
5/8-18	62FRFTFZ			
3/4-10	75CRFTFZ	1.127 - 1.088	1.585 MAX.	.825 MAX.
3/4-16	75FRFTFZ			

NOTES		APPROVAL			FLANGE NUT TECHLOCK GRADE F						
MATL.: STEEL		QC	VC	10-14-05		DATE	DRAWN BY	SCALE	UNITS	DWG. TYPE	REV.
UNLESS OTHERWISE INDICATED, DIMENSIONAL, MECHANICAL AND PERFORMANCE REQUIREMENTS PER IFI 100/107						10-11-05	MP	NONE	INCH	S	0