

REVISIONS

PART NO. RSL2

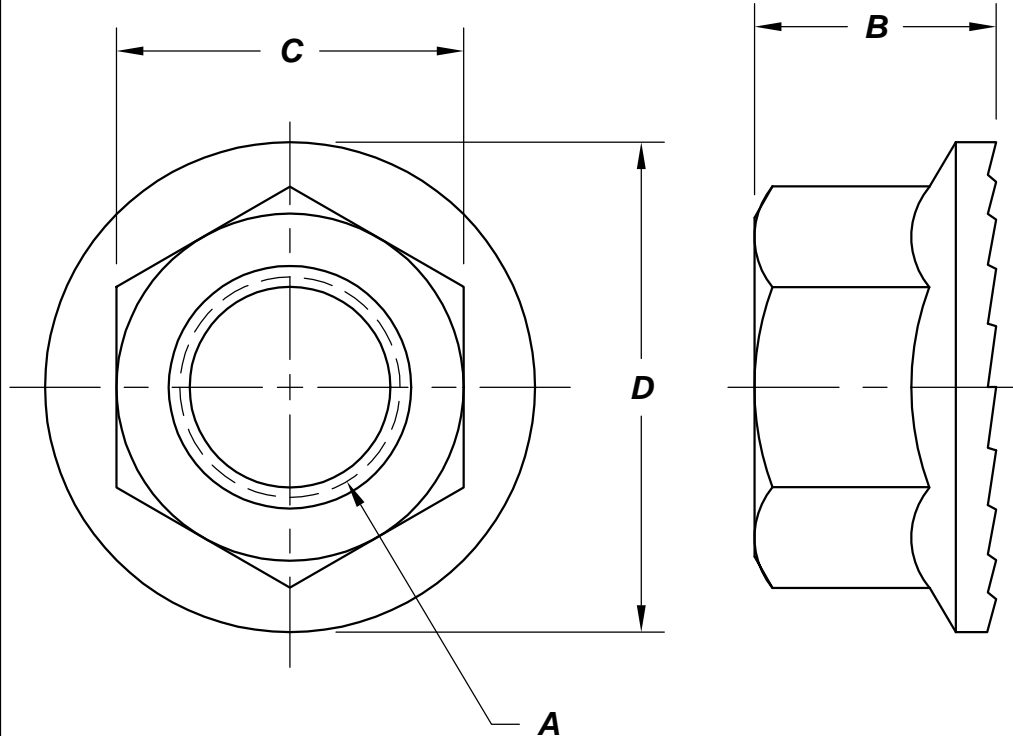

SIZE A	ZINC PLATED PART NUMBER	HEIGHT max / min B	ACROSS FLATS max / min C	FLANGE DIA. max / min D
6-32	6CRSL2Z	.200 - .156	.312 - .302	.447 - .401
8-32	8CRSL2Z	.232 - .187	.344 - .332	.500 - .452
10-24	10CRSL2Z	.240 - .200	.375 - .362	.531 - .480
10-32	10FRSL2Z			
1/4-20	25CRSL2Z	.255 - .222	.438 - .428	.609 - .562
1/4-28	25FRSL2Z			
5/16-18	31CRSL2Z	.297 - .268	.500 - .489	.687 - .641
5/16-24	31FRSL2Z			
3/8-16	37CRSL2Z	.359 - .330	.562 - .551	.750 - .703
3/8-24	37FRSL2Z			
7/16-14	43CRSL2Z	.395 - .375	.688 - .675	.937 - .910
7/16-20	43FRSL2Z			
1/2-13	50CRSL2Z	.458 - .437	.750 - .736	1.062 - 1.000
1/2-20	50FRSL2Z			
5/8-11	62CRSL2Z	.569 - .545	.938 - .922	1.281 - 1.248
5/8-18	62FRSL2Z			

NOTES

APPROVAL

MATL.: STEEL

QC VC 10-26-05

SERRATED FLANGE NUT, GRADE 2



DATE	DRAWN BY	SCALE	UNITS	DWG. TYPE	REV.
10-25-05	MP	NONE	INCH	S	0